

left



right

VOLKSWAGEN 1200 - 1300/2/3 -1500 - BEETLE

1200/ 1300 A

08/1965 - 12/1985

1300/ 1500 BEETLE/ GHIA/ BUGGY

08/1965 - 03/1975



63082
Beetle



63082
Beetle

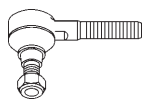

63035

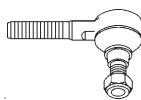

63039

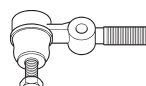

63038

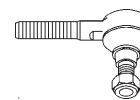

63034



63083
Beetle



63083
Beetle

45830	45046-29115	tre	MM17X1.5L	46081	43330-39295	bj	Taper Ø18.2 mm
45831	45406-29115	tre	M17X1.5R	845607	48632-30020	sb tca	Ext. Ø36.5 - 38 mm
45880	43350-39035	bj	Taper Ø15 mm	845612	48654-35010	sb tca	Ext. Ø40.5 mm
45881	43330-39165	bj	Taper Ø17.9 mm				

1302/ 1303/ A & S

01/1974 - 01/1980

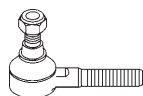

63034

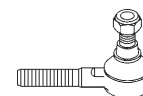

63034



863623



863623



63282

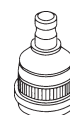

63282

SID Ref	OE Nr		Measures	SID Ref	OE Nr		Measures
63034	311 415 812 B, C	tre i	M14x1,50 RHT M	863623	133 407 183	sb front	
63282	133 407 361	bj l					

SIDEM



© Sidem nv 2005



NEW BEETLE

01/1998 ->

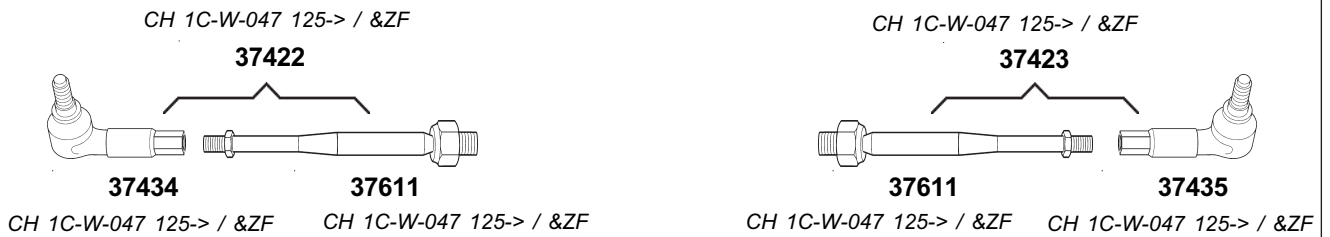
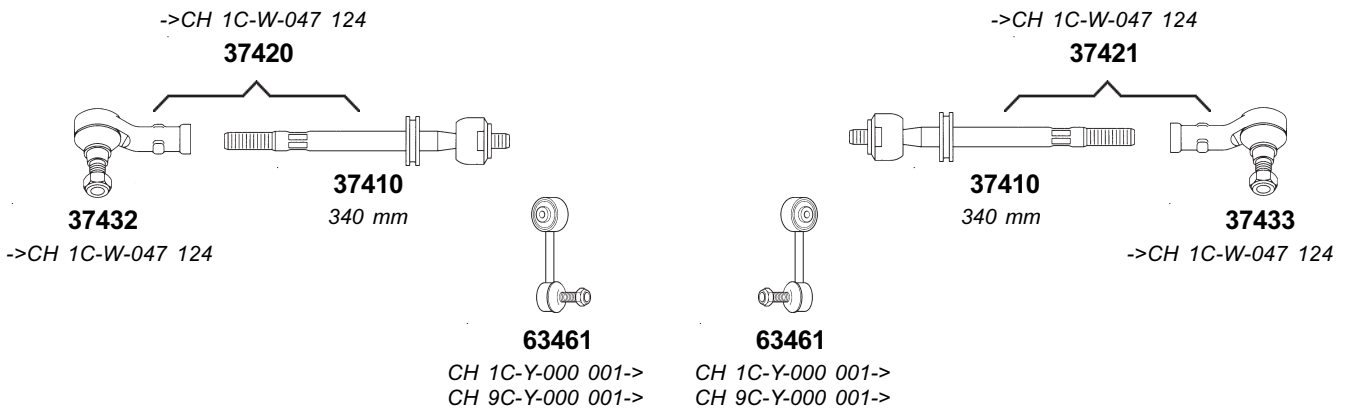

SID Ref	OE Nr		Measures	SID Ref	OE Nr		Measures
37410	1J0 422 807	ax j		37470	1J0 407 151	tca l	
37420	1J0 422 803 A	tr		37471	1J0 407 151	tca l	
37421	1J0 422 804 A	tr		37486	1J0 407 365 A/B/C/D	bj l	
37422	1J0 422 803 B	tr		37487	1J0 407 366 A/B/C/D	bj l	
37423	1J0 422 804 B	tr		37611	1J0 422 803/4 3 B*	ax j	
37432	1J0 422 811 A	tre	M14x1,50 RHT F	63461	1J0 411 315 G	stabl	
37433	1J0 422 812 A	tre	M14x1,50 RHT F	863601	8N0 407 182 A	sb tca	Ext. Ø33.05 mm
37434	1J0 422 811 B	tre		863602	8N0 407 181 B	sb tca	Ext. Ø60 mm
37435	1J0 422 812 B	tre					



left



right

VOLKSWAGEN GOLF - CADDY - JETTA SCIROCCO

GOLF I
GOLF CABRIO
CADDY I
JETTA I
SCIROCCO

08/1974 - 12/1985
01/1979 - 08/1993
08/1982 - 07/1992
08/1979 - 01/1985
02/1974 - 07/1992

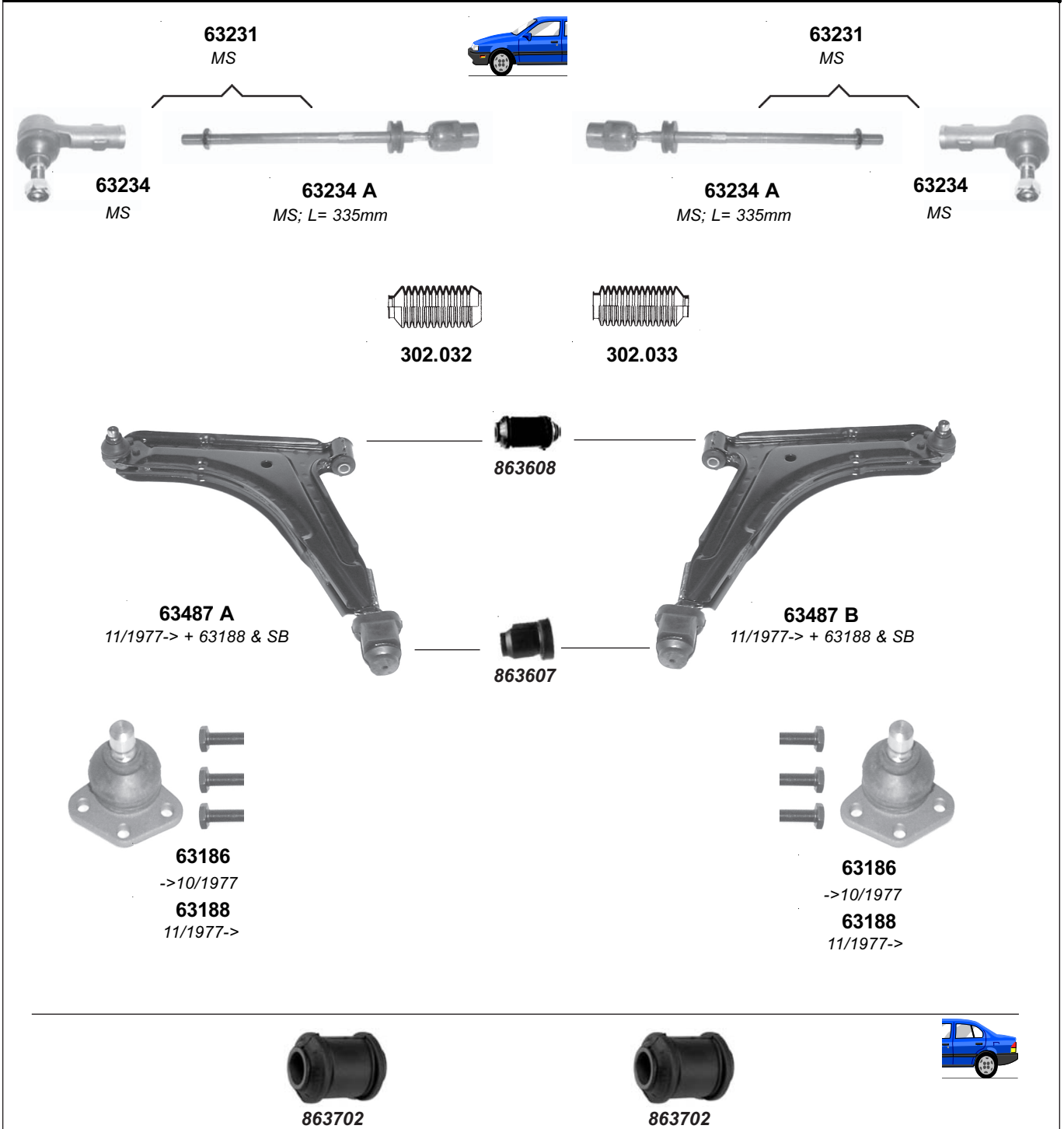

SID Ref	OE Nr		Measures	SID Ref	OE Nr		Measures
63186	171 407 365 C, D	bj l		63487 B	171 407 153 D	tca l	
63188	171 407 365 F, G	bj l		302.032	171 419 831 B	strag	
63231	171 419 804	tr		302.033	171 419 832 A	strag	
63234	171 419 812	tre	M14x1,50 RHT F	863607	171 407 181 A	sb tca e	
63234 A	171 419 821 A	ax j	M14x1,50 RHT M	863608	171 407 182 D	sb tca c	
63487 A	171 407 153 D	tca l		863702	171 501 543	sb	

SIDEM



© Sidem nv 2005

VOLKSWAGEN GOLF II - JETTA II - CORRADO

left



right

GOLF II / SYNCRO / RALLY

08/1984 - 12/1992

JETTA II SYNCRO

01/1984 - 02/1992

CORRADO

08/1989 - 12/1995

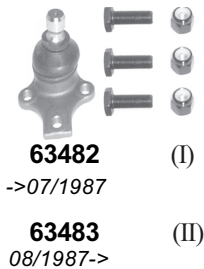
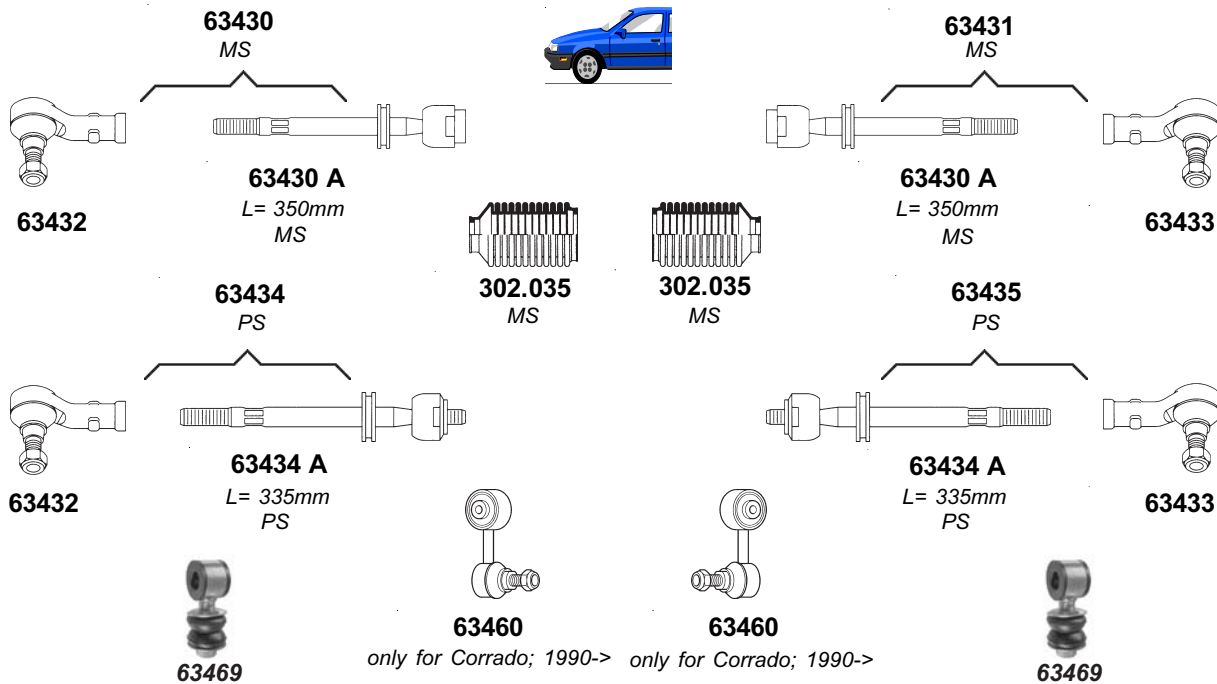

63488 A (+I) 863604
->07/1987; + 63482 & SB
63489 A (+II)
08/1987->; + 63483 & SB

63488 B (+I) 863604
->07/1987; + 63482 & SB
63489 B (+II)
08/1987->; + 63483 & SB

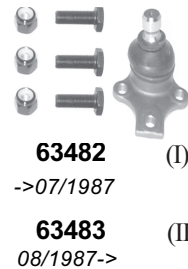

863703

only for Golf II syncro 4x4 GTI / G60



863708



863703

only for Golf II syncro 4x4 GTI / G60

SID Ref	OE Nr		Measures	SID Ref	OE Nr		Measures
63430	191 419 803	tr		63483	357 407 365	bj l	
63430 A	#	ax j	M14x1,50 RHT M	63488 A	191 407 153*	tca l	
63431	191 419 804	tr		63488 B	191 407 153*	tca l	
63432	191 419 811	tre	M14x1,50 RHT F	63489 A	191 407 153*	tca l	
63433	191 419 812	tre	M14x1,50 RHT F	63489 B	191 407 153*	tca l	
63434	191 422 803 A	tr		302.035	191 419 831	strag	
63434 A	#	ax j	M14x1,50 RHT M	863601	191 407 182	sb tca c	
63435	191 422 804 A	tr		863604	191 407 181 D	sb tca e	
63460	535 411 315	stabl		863703	1H0 599 273	sb	
63469	191 411 315 B	stabl		863708	191 501 541	sb	
63482	191 407 365	bj l					



left



right

VOLKSWAGEN GOLF III - VENTO

GOLF III
GOLF CABRIO III
GOLF VARIANT III
VENTO

08/1991 - 08/1997
 07/1993 - 05/1998
 07/1993 - 04/1999
 11/1999 - 09/1998

63436 (I+1) MS
63530 (I+2) PS - ZF
63532 (I+3) PS - TRW

302.035 MS
302.035 MS

63437 (II+1) MS
63531 (II+2) PS - ZF
63533 (II+3) PS - TRW

63432 (I)
63436 A (1) L= 375mm MS
63433 (II)

63530 A (2) L= 365mm PS - ZF
63532 A (3) L= 370mm PS - TRW

63530 A (2) L= 365mm PS - ZF
63532 A (3) L= 370mm PS - TRW

63460
63460

63483 (I)
exc. 16V / VR 6 / Vento GT

63483 (I)
exc. 16V / VR 6 / Vento GT

63485 (II)
only for 16V / VR 6 / Vento GT

63580 A + (I) **863604**
exc. 16V / VR 6 / Vento GT
63584 + (II)

863604 **63580 B** (I) + *only for 16V / VR 6 / Vento GT*
63585 (II) +

+ 63485 & SB *only for 16V / VR 6 / Vento GT* + 63485 & SB *only for 16V / VR 6 / Vento GT*

SID Ref	OE Nr		Measures	SID Ref	OE Nr		Measures
63432	191 419 811	tre	M14x1,50 RHT F	63532	1H0 422 803 A	tr	
63433	191 419 812	tre	M14x1,50 RHT F	63532 A	#	ax j	M14x1,50 RHT M
63436	1H0 419 803	tr		63533	1H0 422 804 A	tr	
63436 A	#	ax j	M14x1,50 RHT M	63580 A	1H0 407 151	tca l	
63437	1H0 419 804	tr		63580 B	1H0 407 151	tca l	
63460	535 411 315	stabl		63584	1H0 407 151 A	tca l	
63483	357 407 365	bj l		63585	1H0 407 152	tca l	
63485	1H0 407 365	bj l		302.035	#	strag	
63530	1H0 422 803 B, C	tr		863601	191 407 182	sb tca c	
63530 A	#	ax j	M14x1,50 RHT M	863604	191 407 181 D	sb tca e	
63531	1H0 422 804 B, C	tr					

© Sidem nv 2005

SIDEM



VOLKSWAGEN GOLF IV - BORA

left right



**GOLF IV
BORA**

08/1997 - 2003
10/1998 ->

- > 1J - WW062359
- > 1J - WB027484
- > 1J - WP050832
- > 1J - WD039150



only Golf IV

- > 1J - WW062359
- > 1J - WB027484
- > 1J - WP050832
- > 1J - WD039150

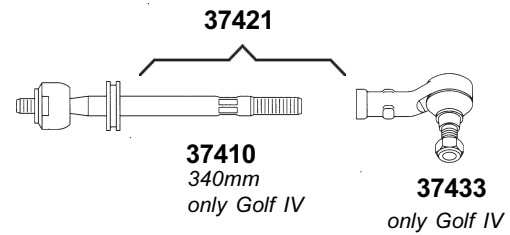
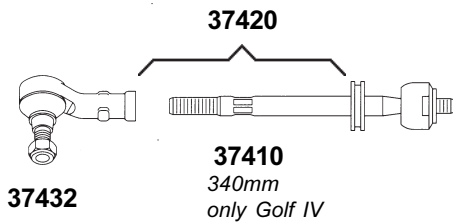

- 1J - WP050833 ->
- 1J - WD039151 ->
- 1J - WB027485 ->
- 1J - WW062360 ->

Bora & Golf IV

- 1J - WP050833 ->
- 1J - WD039151 ->
- 1J - WB027485 ->
- 1J - WW062360 ->

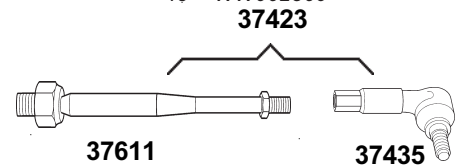
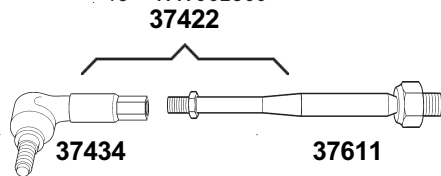

SID Ref	OE Nr		Measures	SID Ref	OE Nr		Measures
37410	1J0 422 803/4A*	ax j		37486	1J0 407 365 C	bj l	Taper Ø14.9 mm
37420	1J0 422 803 A	tr		37487	1J0 407 366 C	bj r	Taper Ø14.9 mm
37421	1J0 422 804 A	tr		37611	1J0 422 803/4B*	ax j	318 mm
37422	1J0 422 803 B	tr		63461	1J0 411 315 G	stabl	105 mm
37423	1J0 422 804 B	tr		63661	1J0 411 315 C	stabl	105 mm
37432	1J0 422 811 A	tre l	FM14X1.5R	63462	1J0 411 315 D	stabl l	336 mm
37433	1J0 422 812 A	tre r	M14X1.5R	63463	1J0 411 316 D	stabl r	
37434	1J0 422 811 B	tre l	FM14X1.5R	863601	8N0 407 182 A	sb tca	Ext. Ø33.05 mm
37435	1J0 422 812 B	tre r	M14X1.5R	863602	8N0 407 181 B	sb tca	Ext. Ø60 mm
37470	1J0 407 151 C	tca	Taper Ø14.9 mm	863704	1J0 501 541 C	sb tca	Ext. Ø72.25 mm
37471	1J0 407 151 C	tca	Taper Ø14.9 mm				



left



right

VOLKSWAGEN GOLF V

GOLF V

1K1

10/2003 ->



63730



63710



63710



63731



63563



63563



63586

+



63770

Cast Iron

63778

Sheet Metal

863631



863631



63771

Cast Iron

63779

Sheet Metal



63587

863632

863633



863901



63775



63775



863901



63564

CH ->1K4350000



63660

CH 1K4350001->



63568



63569



63660

CH 1K4350001->



63564

CH ->1K4350000

SID Ref	OE Nr		Measures	SID Ref	OE Nr		Measures
63563	1K0 411 315 B	stabl		63731	1K0 423 812 A	tre	
63564	1K0 505 465 C	stabl		63770	1K0 407 151 M	tca	
63568	1K0 501 529 F	stabl		63771	1K0 407 152 M	tca	
63569	1K0 501 530 C	stabl		63775	1K0 505 323 H	tca	
63586	1K0 407 365 B/E	bj		863631	1K0 407 182	sb tca c	
63587	1K0 407 366 B	bj		863632	1K0 199 231 G	sb tca e	
63660	1K0 505 465 J	stabl		863633	1K0 199 232 G	sb tca e	
63710	1K0 423 810 A	ax j		863901	1K0 511 327 AP	stabl m	
63730	1K0 423 811 A	tre					

SIDEM



© Sidem nv 2005

379

VOLKSWAGEN CADDY III

left right



CADDY

III

03/2004 ->



63730



63710



63710



63731



63563



63563



63586



63770
Cast Iron

63778
Sheet Metal



863631

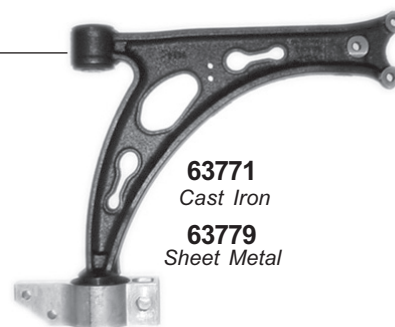

63771
Cast Iron

63779
Sheet Metal



63587



863632



863633



63660



63660



SID Ref	OE Nr		Measures	SID Ref	OE Nr		Measures
63563	1K0 411 315 D	stabl		63770	1K0 407 151 M	tca	
63586	1K0 407 365 C	bj l		63771	1K0 407 152 M	tca	
63587	1K0 407 366 C	bj r		63778	1K0 407 151 P	tca	
63660	2K0 505 465 B	stabl		63779	1K0 407 152 P	tca	
63710	1K0 423 810 A	ax j		863631	1K0 407 182	sb tca	
63730	1K0 423 811 G	tre l		863632	1K0 199 231 G	sb tca	
63731	1K0 423 812 G	tre r		863633	1K0 199 232 G	sb tca	



left



right

VOLKSWAGEN LUPO

LUPO

6X1 / 6E1 except 3L TDI

04/1998 ->

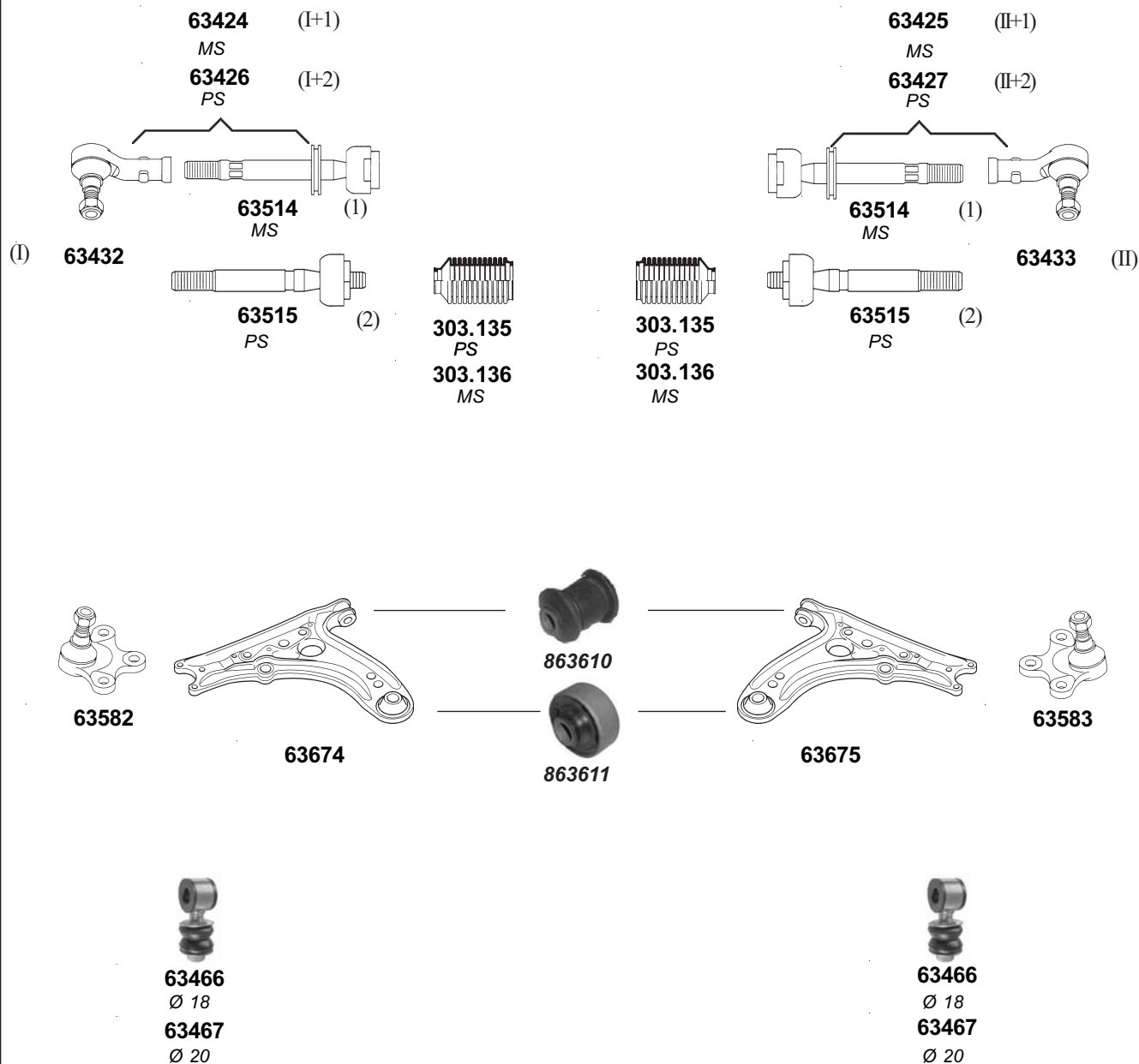

SID Ref	OE Nr		Measures	SID Ref	OE Nr		Measures
303.135	6N0 422 831	strag		63467	6N0 411 315 A	stabl	
303.136	6N0 419 831	strag		63514	6X0 419 803/4 A	ax j	
63424	6X0 419 803 A	tr		63515	6X0 422 803/4 A	ax j	
63425	6X0 419 804 A	tr		63582	6N0 407 365	bj l	
63426	6X0 422 803 A	tr		63583	6N0 407 365 A	bj l	
63427	6X0 422 804 A	tr		63674	6N0 407 151 A	tca l	
63432	6N0 419 811	tre	M14x1,50 RHT F	63675	6N0 407 151 A	tca l	
63433	6N0 419 812	tre	M14x1,50 RHT F	863610	6N0 407 182	sb tca c	
63466	6N0 411 315	stabl		863611	6N0 407 181	sb tca e	

© Sidem nv 2005

SIDEM



381



PASSAT

07/1973 - 07/1980

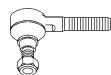

63236



302.032

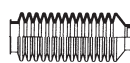

302.033



63380

->08/1977

63382

09/1977->

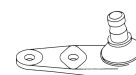

63380

->08/1977

63382

09/1977->

SID Ref	OE Nr		Measures	SID Ref	OE Nr		Measures
63236	811 419 812	tre	M14x1,50 RHT M	302.032	171 419 831 B	strag	
63380	823 407 365 C	bj l		302.033	171 419 832 A	strag	
63382	823 407 365 E	bj l					



left



right

VOLKSWAGEN PASSAT - SANTANA

PASSAT
SANTANA

08/1980 - 07/1990

08/1981 - 12/1984

63237

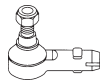

302.034

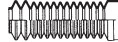

302.034

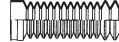

63237

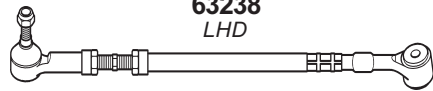
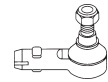

63238
LHD



837607

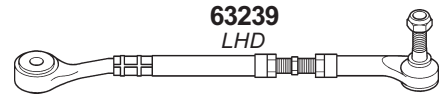

63239
LHD

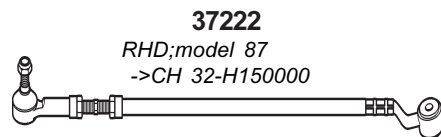

37222
RHD;model 87
->CH 32-H150000

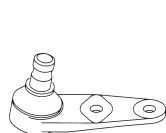

63382
MS

63484

Variant Syncro 1.8

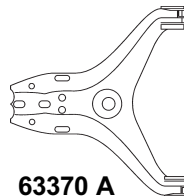

63370 A

MS; + 63382 and SB

63371 A

MS; + 63484 and SB

Variant Syncro 1.8



863615

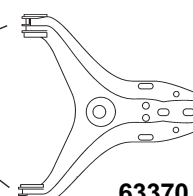

63370 B

MS; + 63382 and SB

63371 B

MS; + 63484 and SB

Variant Syncro 1.8

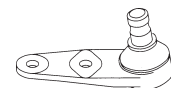

63382
MS

63484

Variant Syncro 1.8



63480
PS

863613

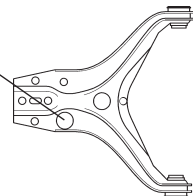

63372

PS; + 63480 and SB



863614

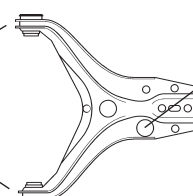

63373

PS; + 63480 and SB



863613

63481
PS



863709



SID Ref	OE Nr		Measures	SID Ref	OE Nr		Measures
37222	812 419 801 A	tr		63382	823 407 365 E	bj l	
63237	811 419 812 A	tre	M14x1,50 RHT F	63480	855 407 365 A, B	bj l	
63238	811 419 801 E	tr		63481	855 407 366 A, B	bj l	
63239	811 419 802 J	tr		63484	853 407 365	bj l	
63370 A	857 407 147 B	tca l		302.034	811 419 831 B	strag	
63370 B	857 407 147 B	tca l		837607	823 411 313 A	stab m	
63371 A	#	tca l		863613	811419809B	sb tca	
63371 B	#	tca l		863614	857 407 181	sb tca	
63372	857 407 147 A	tca l		863615	811 407 181	sb tca	
63373	857 407 148 A	tca l		863709	321 501 541	sb	

SIDEM



© Sidem nv 2005

383



PASSAT/ PASSAT SYNCRO III
PASSAT VARIANT/ VARIANT SYNCRO

03/1988 - 09/1993

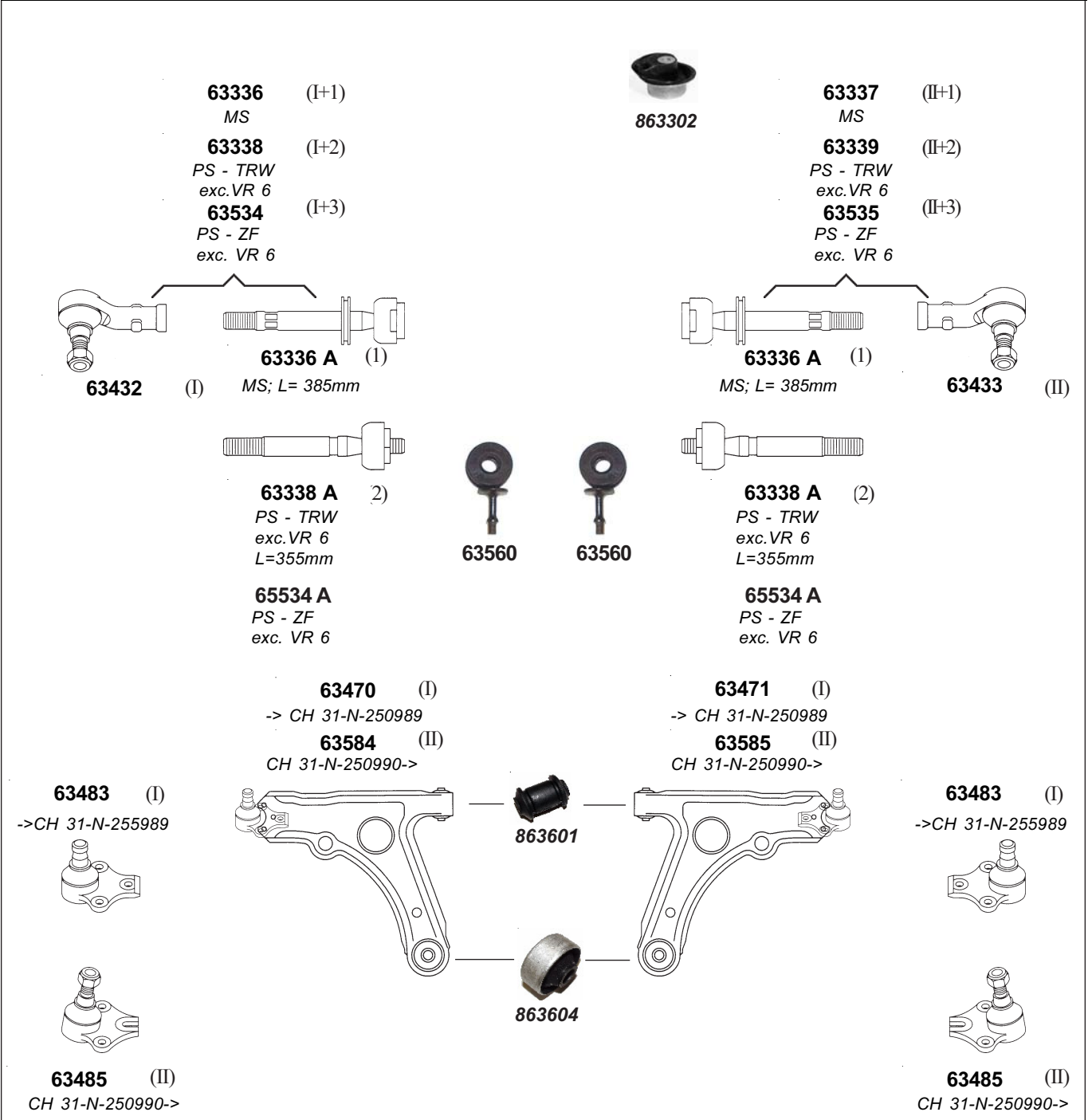

SID Ref	OE Nr		Measures	SID Ref	OE Nr		Measures
63336	357 419 803	tr		63485	1H0 407 365	bj l	
63336 A	#	ax j	M14x1,50 RHT M	63534	357 422 803 A	tr	
63337	357 419 804	tr		63534 A	#	ax j	M14x1,50 RHT M
63338	357 422 803	tr		63535	357 422 804 A	tr	
63338 A	#	ax j	M14x1,50 RHT M	63560	357 411 315 C	stabl	
63339	357 422 804	tr		63584	1H0 407 151 A	tca l	
63432	191 419 811	tre	M14x1,50 RHT F	63585	1H0 407 152	tca l	
63433	191 419 812	tre	M14x1,50 RHT F	863302	357 501 541 A	sb tca c	
63470	357 407 153	tca l		863601	191 407 182	sb tca c	
63471	357 407 151	tca l		863604	191 407 181 D	sb tca e	
63483	357 407 365	bj l					



left



right

VOLKSWAGEN PASSAT

PASSAT

CH 3A-R-0099-265->

10/1993 - 05/1997



SID Ref	OENr		Measures	SID Ref	OENr		Measures
63432	191 419 811	tre	M14x1,50 RHT F	63524	3A0 422 803 C	tr	
63433	191 419 812	tre	M14x1,50 RHT F	63525	3A0 422 804 C	tr	
63470	357 407 153	tca l		63560	357 411 315 C	stabl	
63471	357 407 151	tca l		863302	357 501 541 A	stabl	
63483	357 407 365	bj l		863601	191 407 182	sb tca c	
63512	3A0 422 803, 4 C*	ax j	M14x1,50 RHT M	863604	191 407 181 D	sb tca e	

VOLKSWAGEN PASSAT / PASSAT SYNCRO

left right



PASSAT/ PASSAT SYNCRO	3B2/3B3	08/1996 ->
PASSAT VARIANT/ VARIANT SYNCRO	3B5/3B6	06/1997 ->

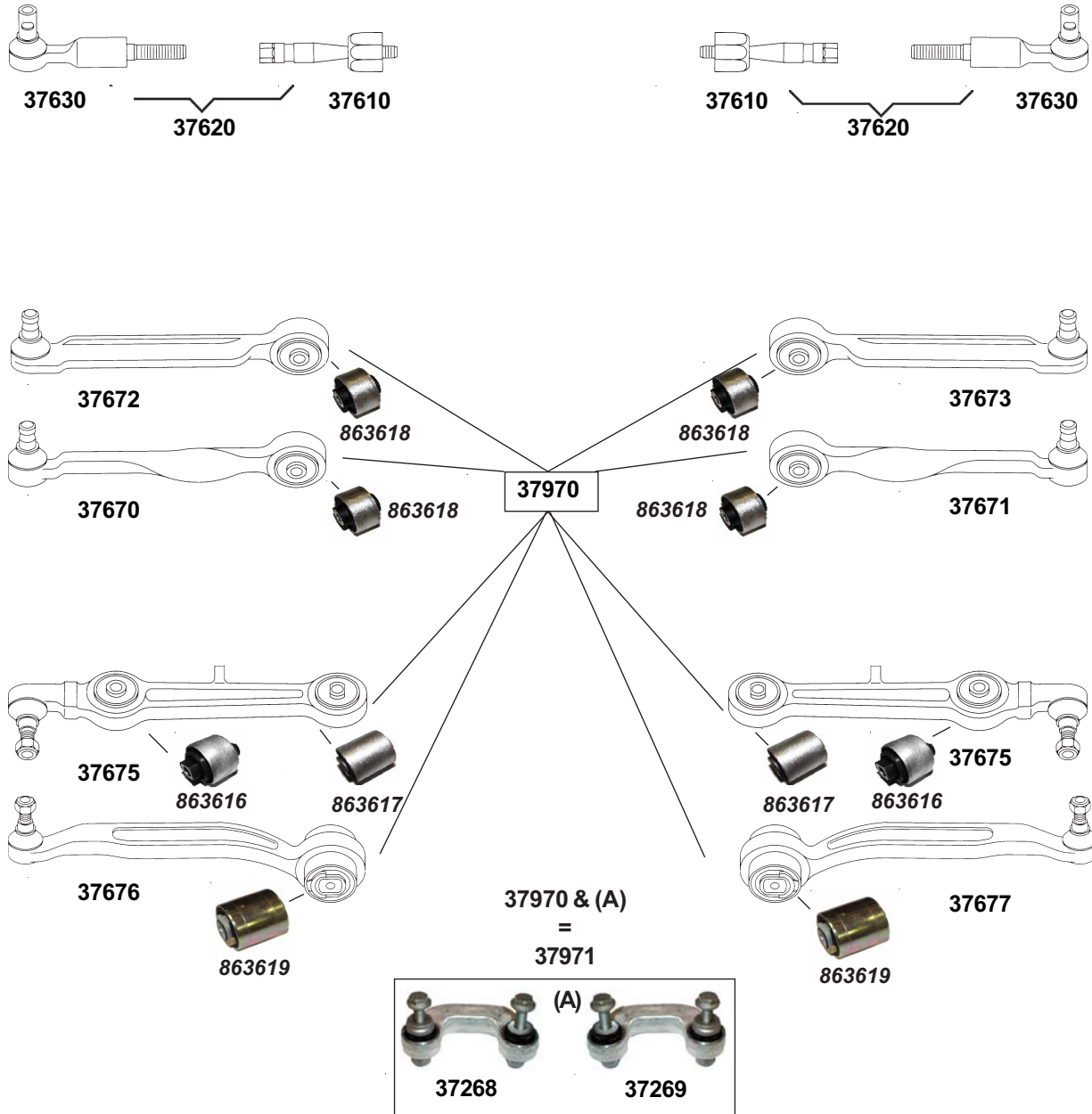

SID Ref	OE Nr		Measures	SID Ref	OE Nr		Measures
37268	8D0 411 317 D	stabl		37675	4D0 407 151 E	tca l	
37269	8D0 411 318 D	stabl		37676	4D0 407 693 E, K	tca l	
37610	4D0 422 821 A	ax j	M14x1,50 RHT M	37677	4D0 407 694 E, K	tca l	
37620	4D0 419 801 Q	tr		37970	8D0 498 998	kit tca	
37630	4D0 419 811 G	tre	M14x1,50 RHT M	37971	#	kit tca	
37670	4D0 407 509 J	tca u		863616	4D0 407 181 H	sb tca c	
37671	4D0 407 510 D	tca u		863617	4D0 407 182 E	sb tca e	
37672	8E0 407 505 A	tca u		863618	4D0 407 515 C	sb tca e	
37673	8D0 407 506 B	tca u		863619	4D0 407 183 P	sb tca e	



left



right

VOLKSWAGEN DERBY - POLO

DERBY

02/1977 - 12/1984

POLO

04/1975 - 09/1994

POLO COUPÈ

10/1981 - 09/1994

POLO CLASSIC

10/1985 - 12/1988

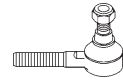
**63236****63333 A**

LHD; 10/1981->

L= 515mm

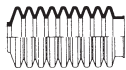
**302.031**

->08/1979

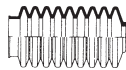
**302.031**

->08/1979

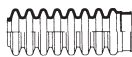
**302.030**

09/1979->

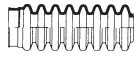
**302.030**

09/1979->

**63333 B**

LHD; ->09/1981; L= 550mm

**863606****863605****63383**

->CH 869-2523-522

63385

CH 869-2523-523->

**863605****863606****63383**

->CH 869-2523-522

63385

CH 869-2523-523->

**863701****863706**

SID Ref	OE Nr		Measures	SID Ref	OE Nr		Measures
63236	811 419 812	tre	M14x1,50 RHT M	302.031	861 419 831 B	strag	
63333 A	871 419 801 A	tr		863605	823 407 181	sb tca c	
63333 B	871 419 802	tr		863606	861 407 183	sb tca e	
63383	861 407 151 A	tca l		863701	861 511 271	sb rear	
63385	861 407 151 B	tca l		863706	6K0 501 541	sb rear	
302.030	861 419 831 A	strag					

SIDEM



© Sidem nv 2005

387



POLO

6N_

10/1994 - 09/2001

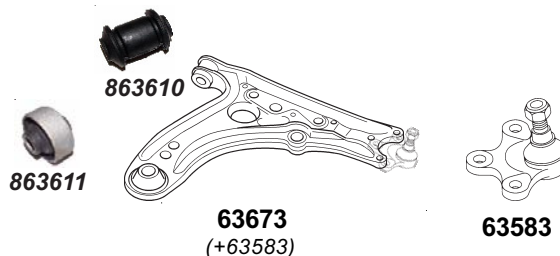
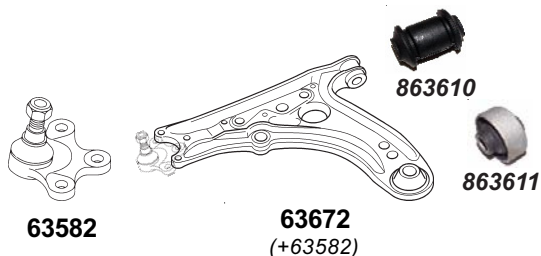
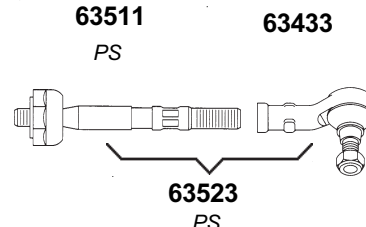
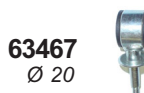
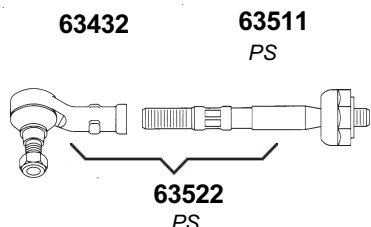
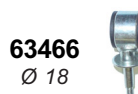
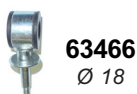
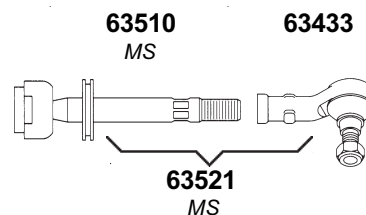
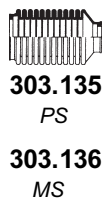
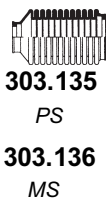
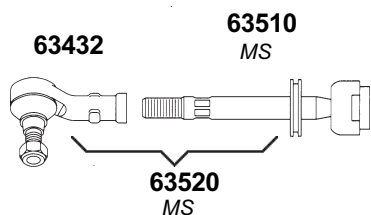

SID Ref	OE Nr		Measures	SID Ref	OE Nr		Measures
63432	6N0 419 811	tre	M14x1,50 RHT F	63582	6N0 407 365	bj l	
63433	6N0 419 812	tre	M14x1,50 RHT F	63583	6N0 407 365 A	bj l	
63466	6N0 411 315 C	stabl		63672	6N0 407 151 (+)	tca l	
63467	6N0 411 315 D	stabl		63673	6N0 407 151 (+)	tca l	
63510	6N0 419 803, 4*	ax j		303.135	6N0 422 831	strag	
63511	6N0 422 803, 4*	ax j		303.136	6N0 419 831	strag	
63520	6N0 419 803	tr		863610	6N0 407 182	sb tca c	
63521	6N0 419 804	tr		863611	6N0 407 181	sb tca e	
63522	6N0 422 803	tr		863706	6K0501541	sb tca e	
63523	6N0 422 804	tr					



left



right

VOLKSWAGEN POLO - CADDY II

POLO CLASSIC	6KV2	05/1996 - 09/2001
POLO VARIANT	6KV5	05/1997 - 09/2001
CADDY II	9K9	11/1995 - 02/2004

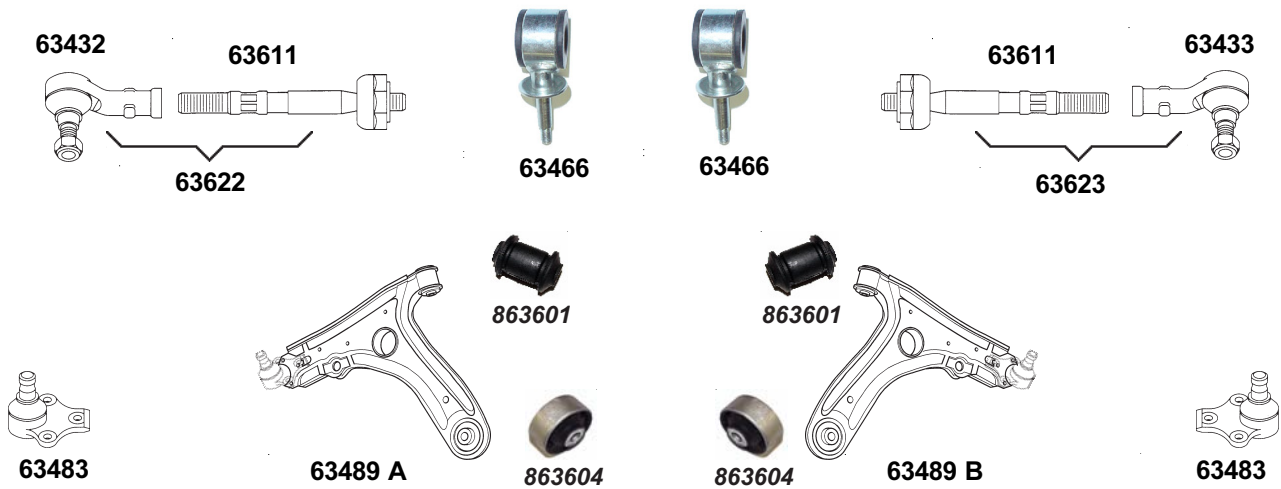

SID Ref	OE Nr		Measures	SID Ref	OE Nr		Measures
63432	3A0 422 811	tre	M14x1,50 RHT F	63623	6K0 422 804 E	tr	
63433	3A0 422 812	tre	M14x1,50 RHT F	63489 A	191 407 151 B	tca l	
63466	6N0 411 315	stabl		63489 B	191 407 151 B	tca l	
63483	357 407 365	bj l		863601	191 407 182	sb tca c	
63611	6K0 422 803/4 E*	ax j		863604	191 407 181 D	sb tca e	
63622	6K0 422 803 E	tr					

POLO 9N1 - 9N1054 10/2001 ->

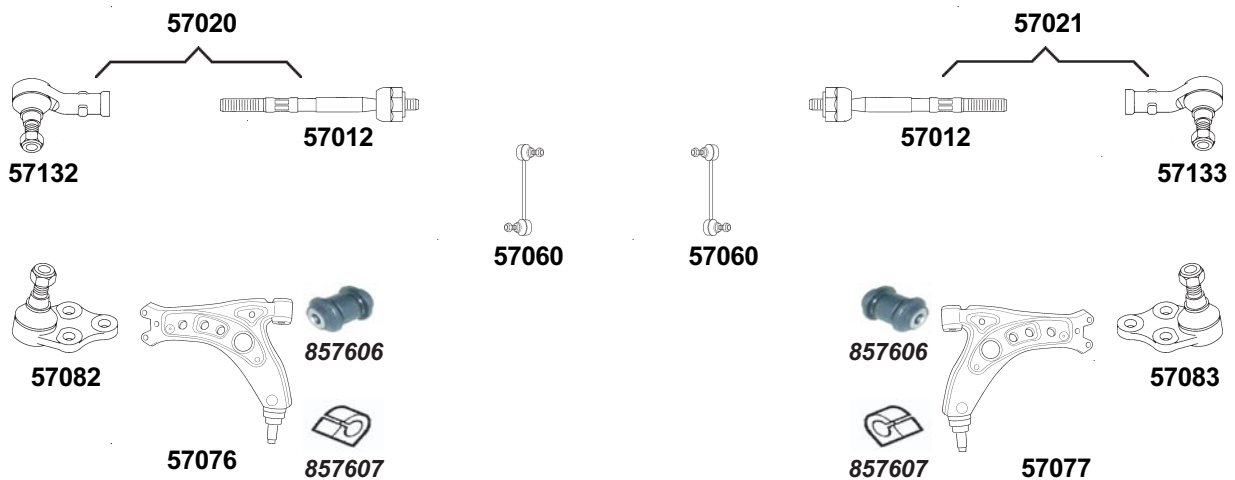

SID Ref	OE Nr		Measures	SID Ref	OE Nr		Measures
57012	#	ax j		57082	6Q0 407 365A	bj l	
57020	6Q0 423 803B	tr		57083	6Q0 407 366A	bj l	
57021	6Q0 423 804B	tr		57132	6Q0 423 811	tre	
57060	6Q0 411 315 C/D	stabl		57133	6Q0 423 812	tre	
57076	6Q0 407 151 D/E (*)	tca		857606	#	sb tca c	
57077	6Q0 407 151 D/E (*)	tca		857607	#	sb tca e	

© Sidem nv 2005

SIDEM



VOLKSWAGEN SHARAN

left right



SHARAN

7M8 / 9

05/1995 ->



3336

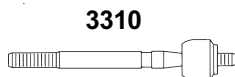

3310



3310

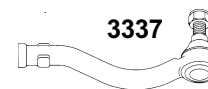

3337



307.230



307.230



3380

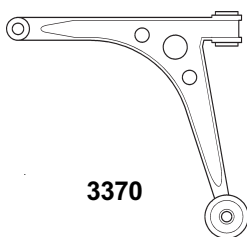

3370



863622



863621



863622



863621

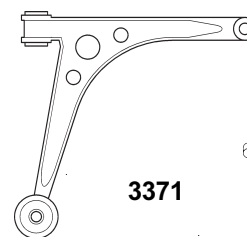

3371



3380

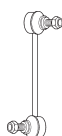

3360



3360



863707



SID Ref	OE Nr		Measures	SID Ref	OE Nr		Measures
3310	#	ax j	M14x1,50 RHT M	3380	7M0 407 365 A	bj l	
3336	7M0 422 817 B	tre	M14x1,50 RHT F	307.230	7M0 422 831 B	strag	
3337	7M0 422 818 B	tre	M14x1,50 RHT F	863621	7M0 407 181 A	sb tca e	
3360	7M0 411 317 D	stabl		863622	7M0 501 541	sb tca c	
3370	7M0 407 151 B	tca l		863707	7M0 505 221 B	sb rear	
3371	7M0 407 152 B	tca l					



left



right

VOLKSWAGEN TOUAREG

TOUAREG

7LA

10/2002 ->

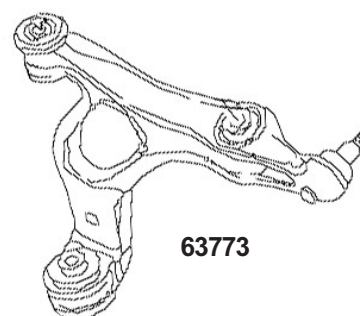
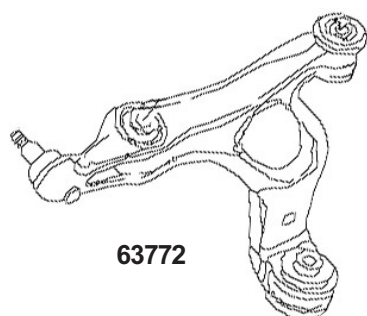
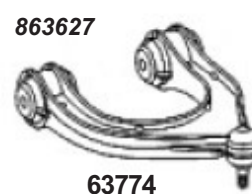
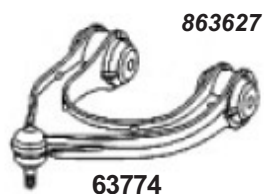

SID Ref	OE Nr		Measures	SID Ref	OE Nr		Measures
63565	7L0 411 317	stabl		63733	7L0 422 818 B	tre	
63613	7L0 422 803/4 B	ax j		63772	7L0 407 151 C/D	tca l	
63626	7L0 422 803 B	tr		63773	7L0 407 152 C/D	tca l	
63627	7L0 422 804 B	tr		63774	7L0 407 021 /A	tca u	
63732	7L0 422 817 B	tre		863627	7L0 412 333 A	sb tca i	

© Sidem nv 2005

SIDEM



VOLKSWAGEN TOURAN

left right



TOURAN

02/2003 ->



SID Ref	OE Nr		Measures	SID Ref	OE Nr		Measures
63563	1K0 411 315 B	stabl		63730	1K0 423 811 A	tre	
63564	1K0 505 465 C	stabl		63731	1K0 423 812 A	tre	
63568	1K0 501 529 F	stabl		63770	1K0 407 151 M	tca	
63569	1K0 501 530 C	stabl		63771	1K0 407 152 M	tca	
63586	1K0 407 365 B/E	bj		63775	1K0 505 323 H	tca	
63587	1K0 407 366 B	bj		863631	1K0 407 182	sb tca c	
63660	1K0 505 465 J	stabl		863632	1K0 199 231 G	sb tca e	
63710	1K0 423 810 A	ax j		863633	1K0 199 232 G	sb tca e	



left



right

VOLKSWAGEN LT 28 / 31/ 35

LT 28 / 31/ 35

04/1975 - 06/1996



863628



864601



864603



864604



864606



863628



64085



64085

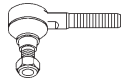

64037

->CH 28-D-004-508

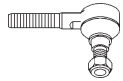

64036

->CH 28-D-004-508

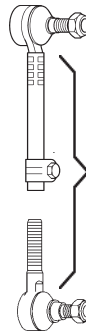

64139

64138



64137

64136 A

64136

CH 28-D-004-508 ->

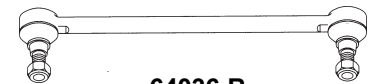

64036 B



64084



850801



64084

SID Ref	OE Nr		Measures	SID Ref	OE Nr		Measures
64036	281 415 811	tre i	M14x1,50 LHT M	64138	281 415 711 A	tre	M16x1,50 RHT M
64036 B	281 415 802 A	tr		64139	281 415 701 E	tr	
64037	281 415 812	tre o	M14x1,50 RHT M	864601	281 407 077	sb front	
64084	281 407 187 B	bj l		864603	281 407 179	sb front	
64085	281 407 361	bj u		864604	281 407 180	sb front	
64136	#	tre i	M16x1,50 RHT F	864606	291 411 045	sb front	
64136 A	281 415 801 D	tr		850801	2D0 411 041 A	sb	
64137	#	tre o	M16x1,50 LHT F				

SIDEM



© Sidem nv 2005

393



LT 40 / 45 04/1975 - 06/1996



64085



864601

64132

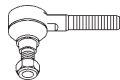

64133

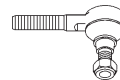

64085

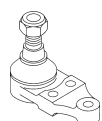

64084

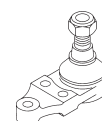

64084

SID Ref	OE Nr		Measures	SID Ref	OE Nr		Measures
64084	281 407 187 B	bj l		64133	291 415 811 B	tre	M18x1,50 LHT M
64085	281 407 361	bj u		864601	281 407 077	sb front	
64132	291 415 711	tre	M18x1,50 RHT M				

LT 28 II - 35 II - 46 II 07/1996 ->



63566



63567

50038

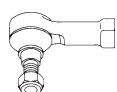

50110

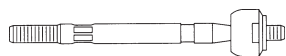

50110

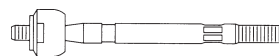

50038

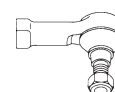

50080



50080



50163

only 28 & 35



50163

only 28 & 35

SID Ref	OE Nr		Measures	SID Ref	OE Nr		Measures
50038	901 460 01 48	tre	M16x1,50 RHT F	50110	901 460 01 55	ax j	M16x1,50 RHT M
50080	901 333 07 27	bj l		50163	2D0 511 329	stabl	
63566	2D0 411 051	stabl		850802	901 323 02 85	stab m	
63567	2D0 411 052	stabl					



left



right

VOLKSWAGEN TRANSPORTER

TRANSPORTER

T2

07/1970 - 04/1979

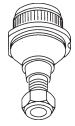

64080



64080

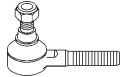

63034

63035

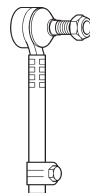
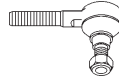

64032

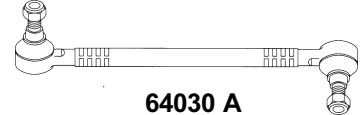

64030 A

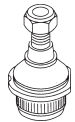

64080

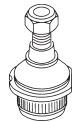

64080

SID Ref	OE Nr		Measures	SID Ref	OE Nr		Measures
63034	113 415 812 C	tre r	M14X1.5R	64032	211 415 712 F	tre	M16X1.5R
63035	311 415 811 B	tre l	M14X1.5L	64080	251 407 187 B	bj up & lo	Taper Ø19.8 mm
64030 A	211 415 802 F	tr					

© Sidem nv 2005

SIDEM



395

VOLKSWAGEN TRANSPORTER

left right



TRANSPORTER	T3	05/1979 - 08/1992
TRANSPORTER SYNCRO	T3	02/1985 - 07/1992

64083



64083



63234

64034 A



64020

64034 A

63234

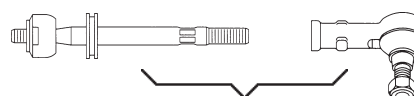

64020

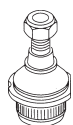

64082



64082



864701



864701

SID Ref	OE Nr		Measures	SID Ref	OE Nr		Measures
63234	171 419 812	tre	MM14X1.5R	64082	251 407 187	bj l	Taper Ø19.7 mm
64020	251 419 803 A	tr		64083	251 407 361	bj up	Taper Ø18.1 mm
64034 A	251 419 803 A	ax j		864701	251 407 077	sb tca	Ext. Ø36 - 57.5 mm



left



right

VOLKSWAGEN TRANSPORTER

TRANSPORTER T4

-> CH 70-S-002791

09/1990 - 08/1994

TRANSPORTER SYNCRO T4

10/1990 - 08/1994



LHD

->CH 70-M-096448

MS

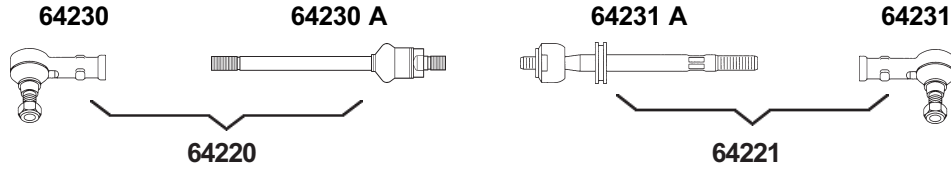

CH 70-M-096449-> / CH 70-S-002791

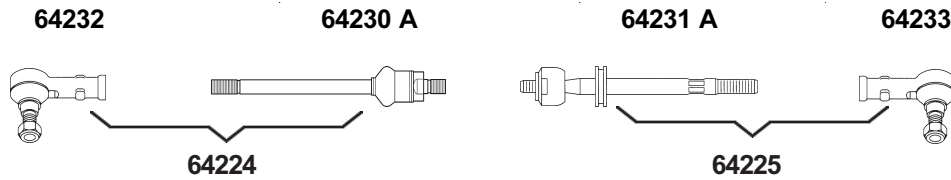

RHD

->CH 70-M-096448

MS

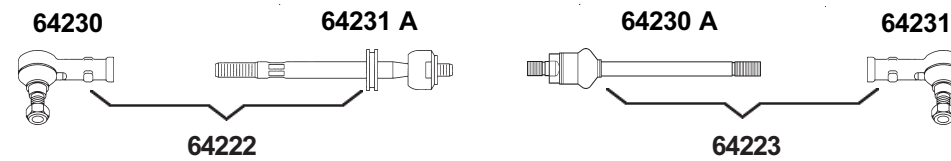

CH 70-M-096449-> / CH 70-S-002791

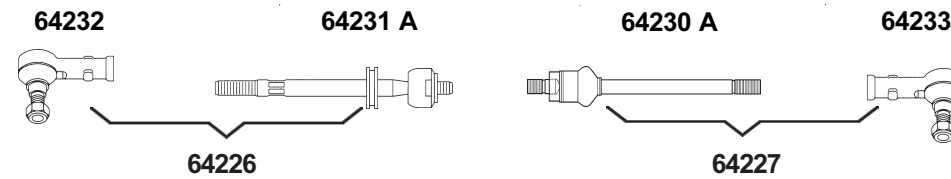

LHD + RHD

->CH 70-M-096448

PS

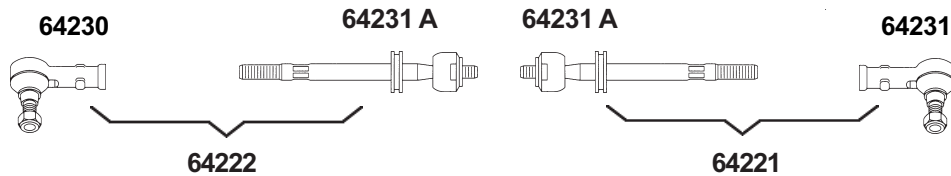

CH 70-M-096449-> / CH 70-S-002791

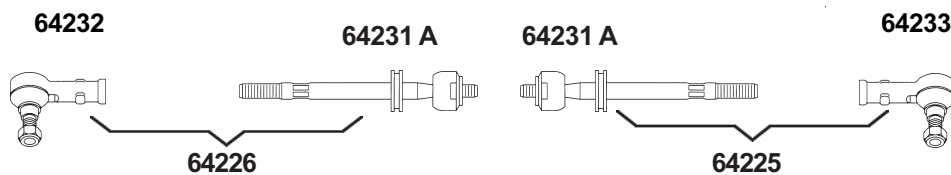

VOLKSWAGEN TRANSPORTER

left right

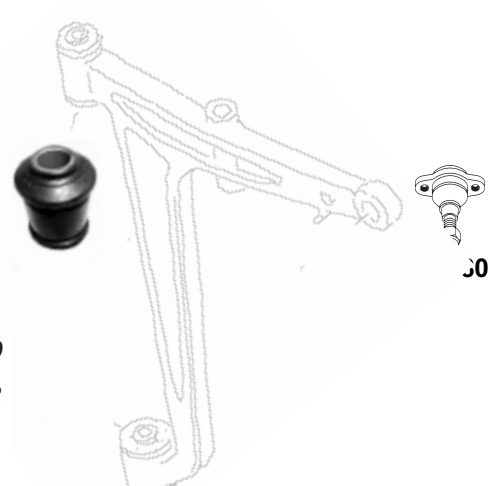
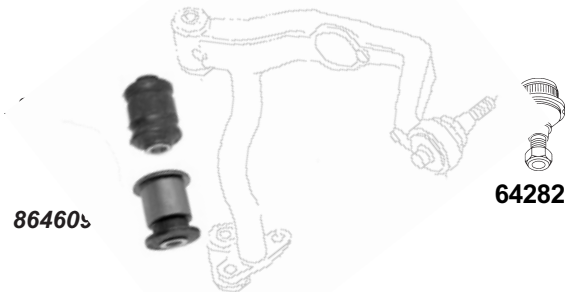
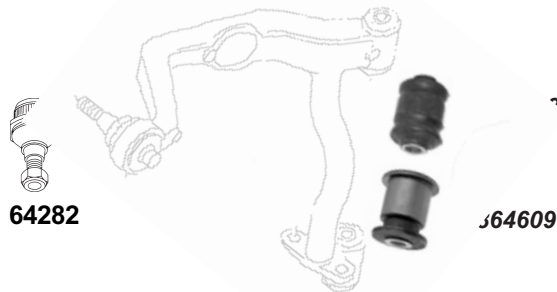

SID Ref	OE Nr		Measures	SID Ref	OE Nr		Measures
63561	7D0 411 049	stabl	108 mm	64232	701 419 811 B	tre l	FM16X1.5R
64220	701 419 803 C	tr		64233	701 419 812 A	tre r	M16X1.5R
64221	701 419 804 C	tr		64280	701 407 361 B	bj lo	Taper Ø20.3 mm
64222	702 419 803 A	tr		64282	701 407 187 B	bj up	Taper Ø17.9 mm
64223	702 419 804 A	tr		64468	701 411 049 B	stabl	L= 108 mm
64224	701 419 803 D	tr		863629	7D0 407 140 A	sb tca	Ext. Ø45.5 mm
64225	701 419 804 D	tr		864608	701 407 077 A	sb tca	
64226	702 419 803 B	tr		864609	701 407 087	sb tca	Ext. Ø35 mm
64227	702 419 804 B	tr		864610	701 407 183	sb tca	Ext. Ø35 mm
64230	701 419 811 A	tre l	FM16X1.5R	864712	701 407 140 A	sb tca	
64230	701 419 811 A	tre l	FM16X1.5R	864804	7D1 411 041	stab m	
64230 A	701 419 810	ax j	295 mm	864805	701 411 041 D	stab m	
64231	701 419 812	tre r	M16X1.5R	864806	7D0 411 045	stab m	
64231 A	701 419 810 B	ax j	294 mm				



left



right

VOLKSWAGEN TRANSPORTER

TRANSPORTER T4

CH 70-S-002792-CH 70-T199999

09/1994 - 12/1995

TRANSPORTER SYNCRO T4

CH 70-S-002792-CH 70-T199999

09/1994 - 12/1995



LHD
MS



RHD
MS

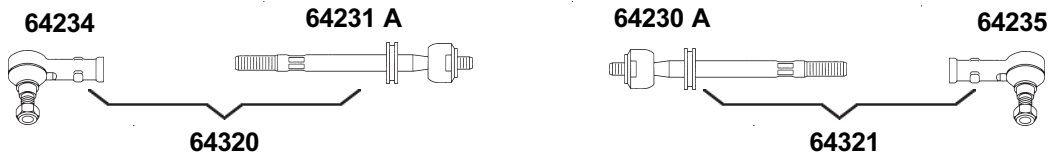

LHD + RHD
PS

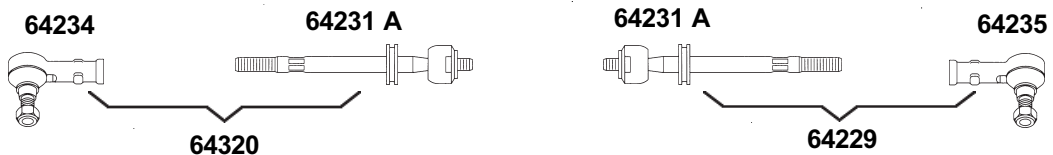

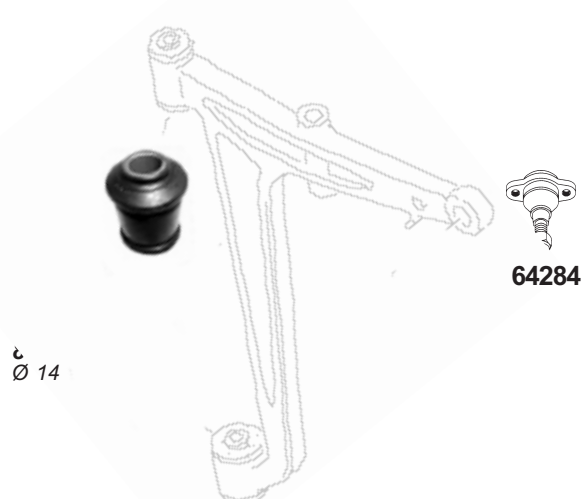
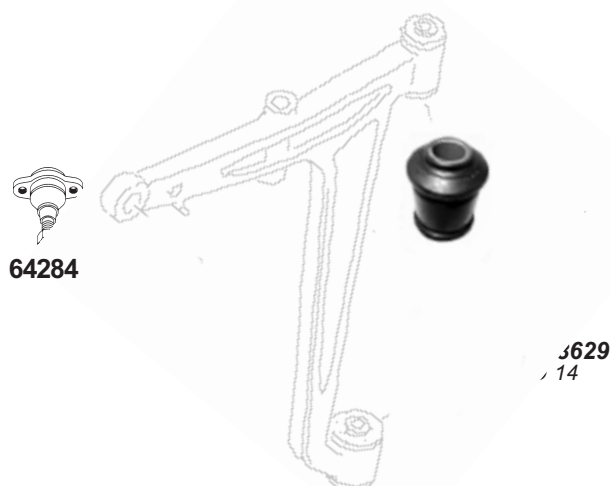
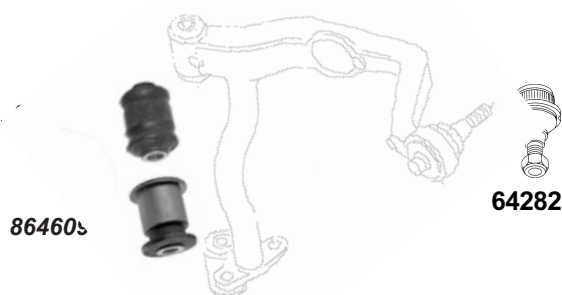
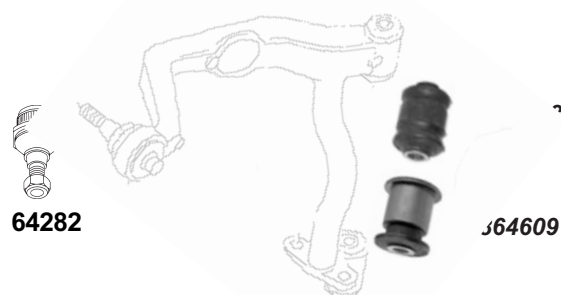

SID Ref	OE Nr		Measures	SID Ref	OE Nr		Measures
63561	7D0 411 049	stabl	L= 108 mm	64320	702 419 803 C	tr	
64228	701 419 803 E	tr		64321	702 419 804 C	tr	
64229	701 419 804 E	tr		863629	7D0 407 140 A	sb tca	Ext. Ø45.5 mm
64230 A	701 419 810	ax j	L= 295 mm	864608	701 407 077 A	sb tca	
64234	701 419 811 C	tre l	FM16X1.5R	864609	701 407 087	sb tca	Ext. Ø35 mm
64235	701 419 812 B	tre r	M16X1.5R	864610	701 407 183	sb tca	Ext. Ø35 mm
64282	701 407 187 B	bj up	Taper Ø17.9 mm	864804	7D1 411 041	stab m	
64284	7D0 407 361	bj lo	Taper Ø20.5 mm	864805	701 411 041 D	stab m	
64231 A	701 419 810 B	ax j	L= 294 mm	864806	7D0 411 045	stab m	
64468	701 411 049 B	stabl	L= 108 mm				



left



right

VOLKSWAGEN TRANSPORTER

TRANSPORTER T4

CH 70-T-200000 ->

01/1996 - 04/2003

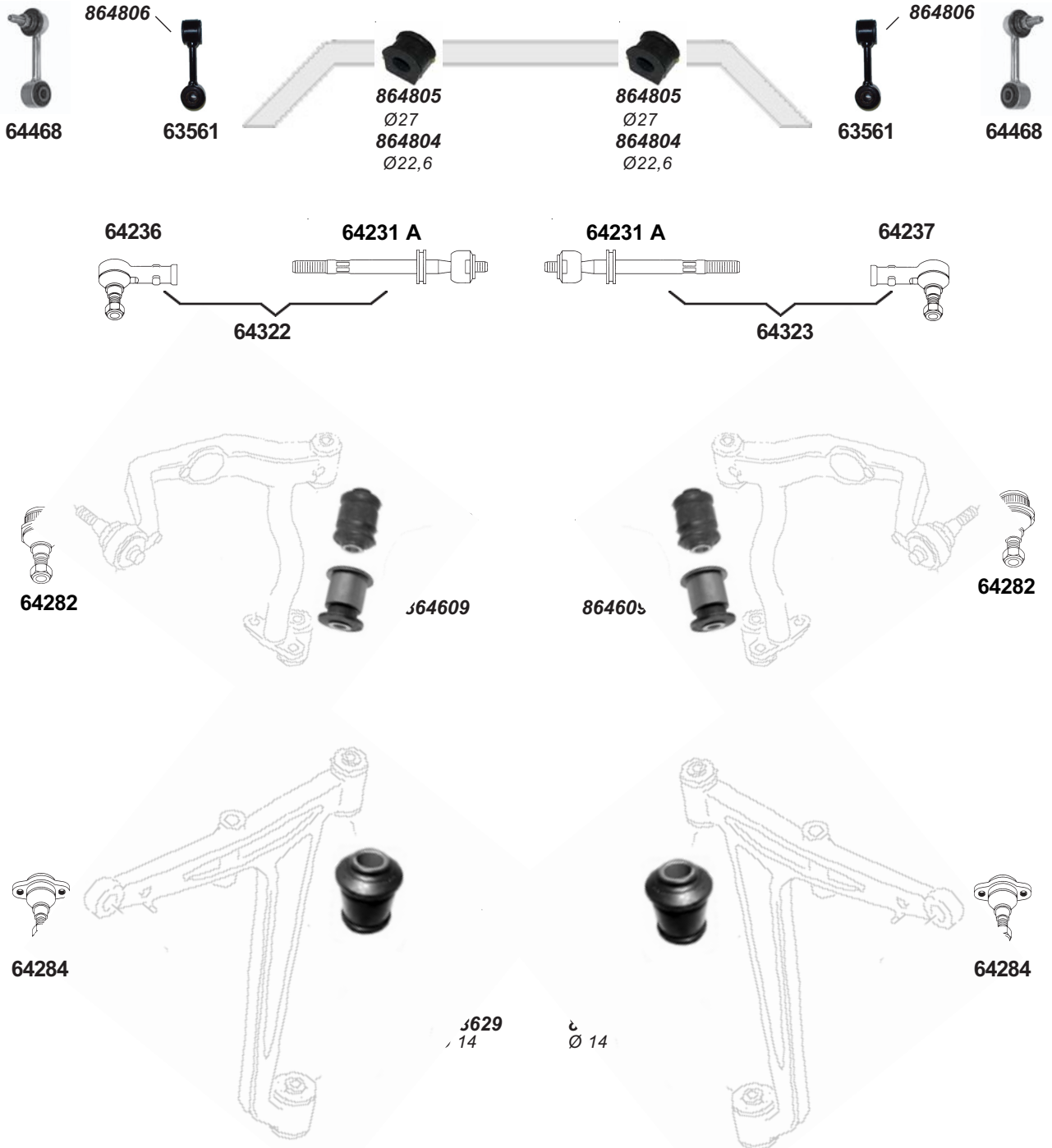

SID Ref	OE Nr		Measures	SID Ref	OE Nr		Measures
63561	7D0 411 049	stabl	108 mm	64468	701 411 049 B	stabl	108 mm
64231 A	701 419 810 B	ax j	294 mm	863629	7D0 407 140 A	sb tca	Ext. Ø45.5 mm
64236	701 419 811 E	tre l	FM16X1.5R	864608	701 407 077 A	sb tca	
64237	701 419 812 D	tre r	M16X1.5R	864609	701 407 087	sb tca	Ext. Ø35 mm
64282	701 407 187 B	bj up	Taper Ø17.9 mm	864610	701 407 183	sb tca	Ext. Ø35 mm
64284	7D0 407 361	bj l	Taper Ø20.5 mm	864804	701 411 041	stab m	
64322	702 419 803 D	tr		864805	701 411 041 D	stab m	
64323	701 419 804 F	tr		864806	7D0 411 045	stab m	

© Sidem nv 2005

SIDEM



401

VOLKSWAGEN MULTIVAN

left right



MULTIVAN T5 04/2003 ->
 TRANSPORTER V (7H_, 7J_) 04/2003 ->



exc. for 3.2 T

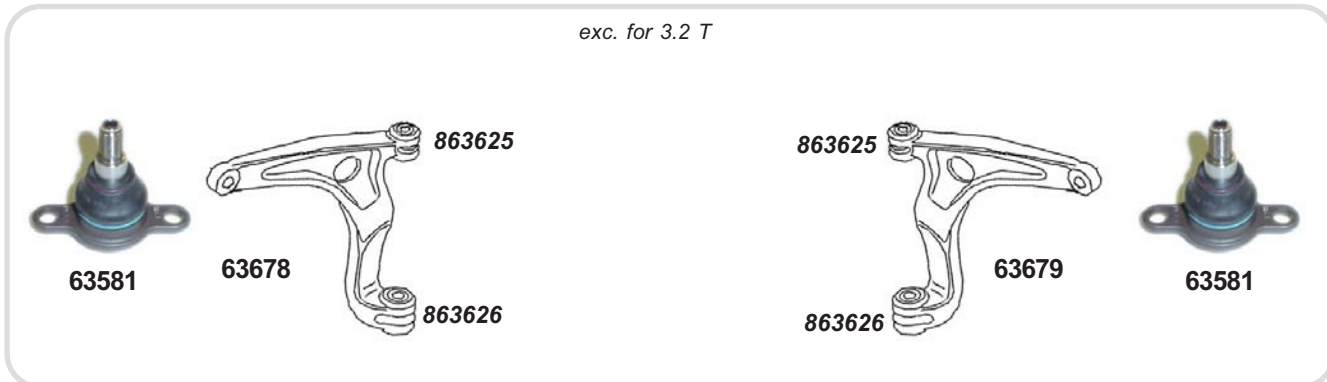

863801



SID Ref	OE Nr		Measures	SID Ref	OE Nr		Measures
63422	7H0 419 803 D	tr		63639	7H0 422 818 C	tre r	M16X1,5 RHT
63423	7H0 419 804 D	tr		63678	7H0 407 151 E	tca	
63562	7H0 411 317	stabl	260 mm	63679	7H0 407 152 E	tca	
63581	7H0 407 361	bj	Taper Ø18 mm	863625	7H0 407 183	sb tca	
63612	7H0 419 803/4 D	ax j	180 MM mm	863626	7H0 407 182 A	sb tca	
63638	7H0 422 817 C	tre l	M16X1,5 RHT	863801	7H0 411 313	stab m	

